

FLIGHT MANUAL

for glider Model

ASW 24

Model : ASW 24
Serial No. : 2 4 0 7 8
Registration : C - G K H U
Data Sheet No. : 04.366
Date of Issue : March 1989

Pages identified "LBA-App." in the original german manual are approved by the German Federal Civil Aviation Authority (LBA) as shown below:

 (Signature)
..... (Authority)
..... (Stamp)
..... (Original Date of Approval)

This sailplane is to be operated in compliance with informations and limitations contained herein.

This translation has been done by best knowledge and judgement. In any case the original text in German is authoritative.

ASW 24 Flight Manual

Published by AS with contributions from Gerhard Waibel and Lutz-Werner Juntow.

Copyright © 1989
Alexander Schleicher GmbH & Co. Poppenhausen/Wasserkuppe
All rights reserved. Reprint or copying -also partially- only with the author's permission.

IMPORTANT NOTE:

The text given in this Manual (including figures, descriptions and operational or handling information) was produced by the authors with great care. However mistakes or misprint as well as misunderstanding can never be excluded. Therefore the authors must state, that juristical responsibility or guaranty or any other warranty which results from mistakes, misprints or misunderstanding cannot be given. The authors however are very grateful to accept advice for corrections.

This Flight Manual is FAA approved for U.S. registered gliders in accordance with the provision of 14 CFR Section 21.29, and is required by FAA Type Certificate Data Sheet No. G84EU and TN 07 .

0.1 Record of Revisions

Any revision of the present manual, except actual weighing data, must be recorded in the following table "Record Of Revisions" (pages 0.2/0.3) and in case of approved Sections endorsed by the LBA.

The new or amended text in the revised page will be indicated by a black vertical line in the left margin, and the Rev.No. and the Date will be shown in the box at the bottom left of the page.

Rev.No./Date Sig.
TN07/ 25.04.94 Juw

Author Date
Waibel March 89

Page No.
0 . 1

ASW 24 Flight Manual

Record of Revisions

Rev. No.	Section Affected	Page(s) Affected	Rev. Date	Approval	Date	Date of Insertion	Signature
TN 2	0	0.4	08.02.90	/	06.04.90	15.05.90	<i>R.W. Juw</i>
	2	2.6	08.02.90	LBA-Appr.	06.04.90	15.05.90	
	6	6.4; 6.5	08.02.90	/	06.04.90	15.05.90	
TN 5	0	0.4	30.01.92	LBA-Appr.	09.04.92	15.04.92	<i>R.W. Juw</i>
	2	2.7; 2.8	30.01.92				
	2	2.9	30.01.92				
TN 6	0	0.4, 0.5	18.08.92	LBA-Appr.	20.10.92	05.06.02	/gr
	1	1.4					
	4	4.2, 4.4					
		4.6, 4.12					
		4.13, 4.14					
TN 7	8	8.3	25.06.94	LBA-Appr.	05.07.94	05.06.02	/gr
	0	0.1, 0.4					
	4	4.11, 4.14					
TN 9	6	6.4, 6.6	23.06.94	LBA-Appr.	01.12.94	05.06.02	/gr
	0	0.4, 0.5					
	3	3.6					
	4	4.15, 4.17					
	7	7.10, 7.11					

Rev. no./Date Sig. Author Date Page no.
 TN09 23.06.94 Juw Waibel March 89 0.2

ASW 24 Flight Manual

0.2 List of Effective Pages

Section	Page	Date	Section	Page	Date	
0	Title	07.03.89		LBA-App. 4.6	18.08.92	
	0.1	25.04.94		LBA-App. 4.7	07.03.89	
	0.2	07.03.89		LBA-App. 4.8	07.03.89	
	0.3	07.03.89		LBA-App. 4.9	07.03.89	
	0.4	23.06.94		LBA-App. 4.10	07.03.89	
	0.5	23.06.92		LBA-App. 4.11	25.04.94	
	0.6	07.03.89		LBA-App. 4.12	18.08.92	
1	1.1	07.03.89		LBA-App. 4.13	18.08.92	
	1.2	07.03.89		LBA-App. 4.14	25.04.94	
	1.3	07.03.89		LBA-App. 4.15	23.06.94	
	1.4	18.08.92		LBA-App. 4.16	07.03.89	
	1.5	07.03.89		LBA-App. 4.17	23.06.94	
	1.6	07.03.89		LBA-App. 4.18	25.04.94	
2	LBA-App. 2.1	07.03.89		LBA-App. 4.19	07.03.89	
	LBA-App. 2.2	07.03.89		LBA-App. 4.20	18.08.92	
	LBA-App. 2.3	07.03.89		LBA-App. 4.21	18.08.92	
	LBA-App. 2.4	07.03.89		5	LBA-App. 5.1	07.03.89
	LBA-App. 2.5	07.03.89			LBA-App. 5.2	07.03.89
	LBA-App. 2.6	08.02.90			LBA-App. 5.3	07.03.89
	LBA-App. 2.7	30.01.92			LBA-App. 5.4	07.03.89
	LBA-App. 2.8	30.01.92			LBA-App. 5.5	07.03.89
	LBA-App. 2.9	30.01.92		LBA-App. 5.6	07.03.89	
3	LBA-App. 3.1	07.03.89		LBA-App. 5.7	07.03.89	
	LBA-App. 3.2	07.03.89		LBA-App. 5.8	07.03.89	
	LBA-App. 3.3	07.03.89		LBA-App. 5.9	07.03.89	
	LBA-App. 3.4	07.03.89		6	LBA-App. 6.1	07.03.89
	LBA-App. 3.5	07.03.89			LBA-App. 6.2	07.03.89
	LBA-App. 3.6	23.06.94			LBA-App. 6.3	07.03.89
4	LBA-App. 4.1	07.03.89		LBA-App. 6.4	25.04.94	
	LBA-App. 4.2	18.08.92		LBA-App. 6.5	08.02.90	
	LBA-App. 4.3	07.03.89		LBA-App. 6.6	25.04.94	
	LBA-App. 4.4	18.08.92		7	LBA-App. 7.1	07.03.89
	LBA-App. 4.5	07.03.89			LBA-App. 7.2	07.03.89

Rev.No./Date. Sig. Author Date Page No.
 TN09 23.06.94 Juw Waibel March 89 0.4

ASW 24 Flight Manual

Section	Page	Date	Section	Page	Date
	7.3	07.03.89			
	7.4	07.03.89			
	7.5	07.03.89			
	7.6	07.03.89			
	7.7	07.03.89			
	7.8	07.03.89			
	7.9	07.03.89			
	7.10	23.06.94			
	7.11	23.06.94			
	7.12	07.03.89			
	7.13	07.03.89			
8	8.1	07.03.89			
	8.2	07.03.89			
	8.3	18.08.92			
	8.4	07.03.89			
	8.5	07.03.89			
	8.6	07.03.89			
	8.7	07.03.89			
9	9.1	07.03.89			
	9.2	07.03.89			

Rev.No./Date. Sig.
TN09 23.06.94 Juw

Author Date
Waibel March 89

Page No.
0.5

ASW 24 Flight Manual

0.3 Table of Contents

	<u>Section</u>
General (a non-approved section)	1
Limitations (an approved section)	2
Emergency Procedures (an approved section)	3
Normal Procedures (an approved section)	4
Performance (a partly approved section)	5
Weight and Balance / Equipment List (a non-approved section)	6
Sailplane and Systems Description (a non-approved section)	7
Sailplane Handling, Care and Maintenance (a non-approved section)	8
Supplements	9

Rev.no./Date Sig.

Author Date
Waibel March 89

Page no.
0.6

ASW 24 Flight Manual

SECTION 1

1. General
- 1.1 Introduction
- 1.2 Certification Basis
- 1.3 Warnings, Cautions and Notes
- 1.4 Descriptive Data
- 1.5 Three-view Drawing

Rev.no./Date	Sig.	Author	Date	Page no.
		Waibel	March 89	1.1

ASW 24 Flight Manual

1.1 Introduction

This Sailplane Flight Manual has been prepared to provide pilots and instructors with information for the safe and efficient operation of the ASW 24 sailplane.

This Manual includes the material required to be furnished to the pilot by JAR-22. It also contains supplemental data supplied by the sailplane manufacturer.

1.2 Certification Basis

This type of sailplane has been approved by the German Federal Civil Aviation Authority (LBA) in accordance with Joint Airworthiness Requirements for Sailplanes and Powered Sailplanes JAR-22 incl. amendments to 15.12.1982 and including Amendment 22/84/1.

The Type Certificate No. 04.366 has been issued on 07 March 1989 Airworthiness Category "U".
U stands for Utility and refers to sailplanes used in normal gliding operation.

1.3 Warnings, Cautions and Notes

The following definitions apply to warnings, cautions and notes used in the Flight Manual:

Rev.no./Date	Sig.	Author	Date	Page no.
		Waibel	March 89	1.2

ASW 24 Flight Manual

"WARNING"



means that the non-observation of the corresponding procedure leads to an immediate or important degradation of the flight safety.

"CAUTION"



means that the non-observation of the corresponding procedure leads to a minor or to a more or less long term degradation of the flight safety.

"NOTE"



draws the attention on any special item not directly related to safety, but which is important or unusual.

1.4 Descriptive Data

The ASW 24 is a high performance single-seater the design of which was orientated to the FAI Standard Class specification.

The ASW 24 is suitable for record breaking and competition flying. Not least, its pleasant flying characteristics make the ASW 24 suitable for use in performance-orientated clubs.

The ASW 24 is a shoulder wing glider with stabilised T-tail (tailplane-plus-elevator) and sprung, retractable landing gear with hydraulic disc brake.

Rev.no./Date	Sig.	Author	Date	Page no.
		Waibel	March 89	1.3

ASW 24 Flight Manual

Optional operation of the ASW 24 with 0,3m (about one foot) high winglets is approved.

Technical Data:

	(metric system)
Span	15.00 m
Fuselage length	6.55 m
Height (Fin and Tail Wheel)	1.30 m
Max.Take-Off Mass	500.00 kg
Wing chord (mean aerodynamic)	0.71 m
Wing area	10.00 m ²
Height of winglet	0.30 m
Wing loadings -	
- min.	30.5 kg/m ²
- max.	50.0 kg/m ²

	(British system)
Span	49.22 ft
Fuselage length	21.49 ft
Height (Fin and Tail Wheel)	4.27 ft
Max.Take-Off Mass	1102.00 lbs
Wing chord (mean aerodynamic)	2.33 ft
Wing area	107.64 ft ²
Height of winglet	11.81 inches
Wing loadings -	
- min.	6.25 lbs/ft ²
- max.	10.24 lbs/ft ²

Rev.No./Date	Sig.	Author	Date	Page No.
TN 6 / 18.08.92	Juw	Waibel	March 89	1.4

Figure 1.4-1 General View

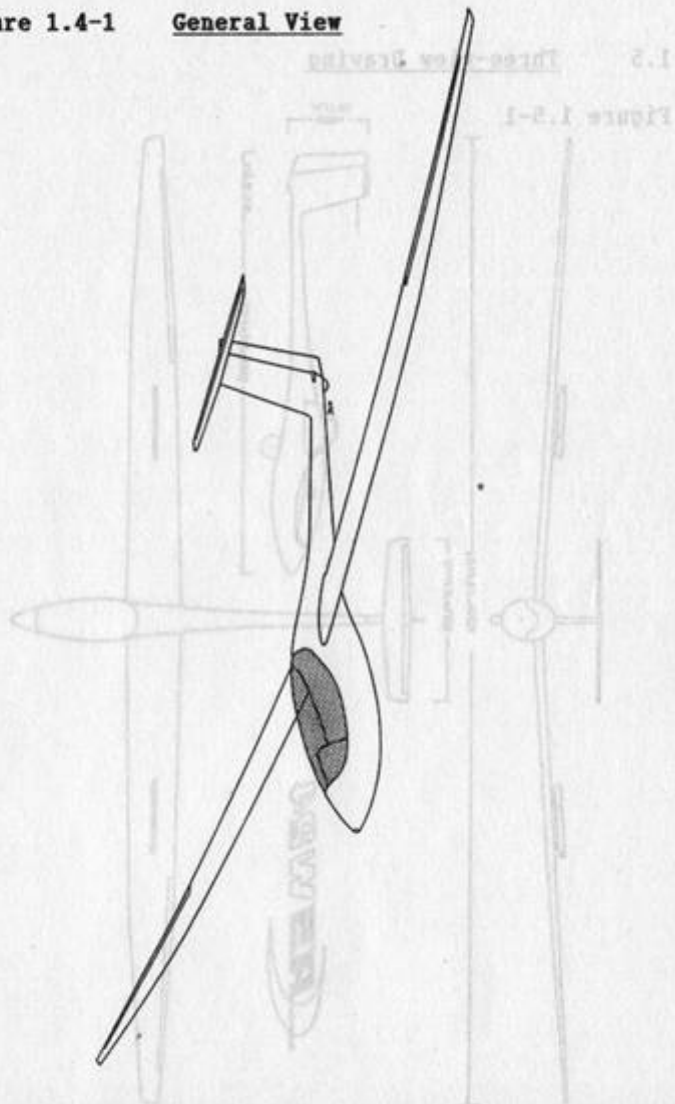

Rev. no./Date	Sig.	Author	Date	Page no.
		Waibel	March 89	1 - 5

1.5 Three-view Drawing

Figure 1.5-1

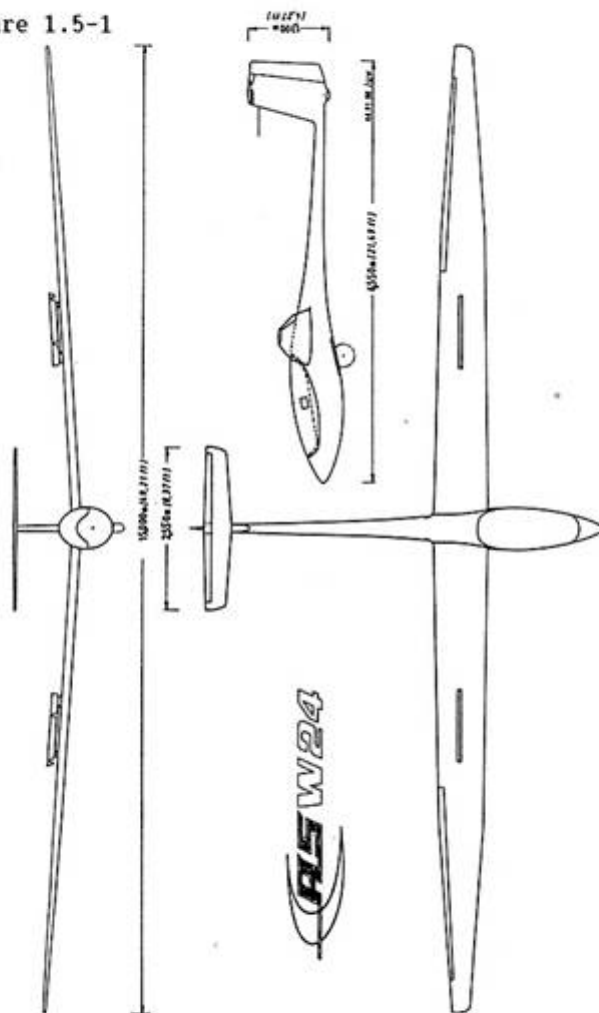

Rev. no./Date	Sig.	Author	Date	Page no.
		Waibel	March 89	1 - 6

SECTION 2

2. Limitations

- 2.1 Introduction
- 2.2 Airspeed
- 2.3 Airspeed Indicator Markings
- 2.4 Mass (Weight)
- 2.5 Centre of Gravity
- 2.6 Approved Manoeuvres
- 2.7 Manoeuvring Load Factors
- 2.8 Flight Crew
- 2.9 Kinds of Operation
- 2.10 Minimum Equipment
- 2.11 Aerotow and Winch Launching
- 2.12 Limitations Placards

Rev.no./Date	Sig.	Author	Date	Page no.
		Waibel	March 89	2.1 LBA-App.

2.1 Introduction

Section 2 includes operating limitations, instrument markings and basic placards necessary for the safe operation of the ASW 24, its standard systems and standard equipment.

The limitations included in this Section and in Section 9 have been LBA-approved.

2.2 Airspeed

Air speed limitations and their operational significance are shown below:-

	Speed	IAS km/h and (kts)	Remarks
VNE	Never exceed speed	280 (151)	Do not exceed this speed in any operation and do not use more than 1/3 of control deflection

Rev.no./Date	Sig.	Author	Date	Page no.
		Waibel	March 89	2.2 LBA-App.

ASW 24 Flight Manual

	Speed	IAS km/h and (kts)	Remarks
VRA	Rough air speed	205 (110,5)	Do not exceed this speed except in smooth air, and then only with caution. Examples of rough air are lee-wave rotor, thunderclouds etc.
V _A	Manoeuvring speed	205 (110,5)	Do not make full or abrupt control movement above this speed, because under certain conditions the sailplane may be overstressed by full control movement.
VW	Maximum winch-launching speed	140 (75,5)	Do not exceed this speed during winch- or autotow-launching

Rev.no./Date Sig.

Author Date
Waibel March 89Page no.
2.3
LBA-App.

ASW 24 Flight Manual

	Speed	IAS km/h and (kts)	Remarks
V _T	Maximum aerotowing speed	180 (97)	Do not exceed this speed during aerotowing.
V _{LO}	Maximum landing gear operating speed	205 (110,5)	Do not extend or retract the landing gear above this speed.

Rev.no./Date Sig.

Author Date
Waibel March 89Page no.
2.4
LBA-App.

2.3 Airspeed Indicator Markings

Airspeed indicator markings and their colour-code significance are shown below:

Marking	(IAS) value or range km/h and (kts)	Significance
Green Arc	102 - 205 (55 - 110,5)	<u>Normal Operating Range.</u> (Lower limit is maximum weight 1.1 V_{s1} at most forward c.g. Upper limit is rough air speed)
Yellow Arc	205 - 280 (110,5 - 151)	Manoeuvres must be conducted with caution and only in smooth air.
Red Line	280 (151)	Maximum speed for all operations.
Yellow triangle	95 (51,5)	Approach speed at maximum weight without water ballast.

Rev.no./Date	Sig.	Author	Date	Page no.
		Waibel	March 89	2 - 5 LBA-APP.

2.4 Mass (Weight)

Maximum Take-Off Mass:

-with water ballast 500 kg (1102 lbs)
-without water ballast 365 kg (804,8 lbs)

Maximum Landing Mass:

500 kg (1102 lbs)
Max. mass of all non-lifting parts 245 kg (507 lbs)
Max. mass in the upper baggage compartment: 15 kg (33 lbs)
Max. mass in the lower baggage compartment: 10 kg (22 lbs)

2.5 Centre of Gravity

Centre of gravity range (for flight):

forward limit 0.24 m (0,79 ft) aft of RP
aft limit 0.37 m (1,21 ft) aft of RP

"RP" stands in this context for "Reference Datum Point" which is situated at the wing leading edge at the wing root rib.

An example of the C.G. position calculation and a table of c.g. ranges at different empty weights can be found in Section 6 of the ASW 24 Maintenance Manual.

2.6 Approved Manoeuvres

This glider is approved for use in normal gliding operation (Airworthiness Category "Utility").

Within this Airworthiness Category U the following aerobatic figures are approved for the ASW 24:-
Lazy Eight, Chandelle, Stall Turn, Steep Turn and positive Loop. Further details concerning these manoeuvres will be found in Section 4.5.9.

Rev.no./Date	Sig.	Author	Date	Page no.	
TN 2	08.02.90	Juw	Waibel	March 89	2 - 6 LBA-APP.

2.7 Manoeuvring Load Factors

Maximum permissible maneuvering load factors:

- maximum positive load factor - 5.3
- maximum negative load factor - 2.65

at an air speed of: 205 km/h (110,5 kts)

At increasing air speeds, these values will be reduced to:

Maximum positive load factor + 4

Maximum negative load factor - 1.5

at an air speed of: 280 km/h (151 kts)

2.8 Flight Crew

The crew of the ASW 24 is one pilot.

Pilots weighing less than 70 kg = 154,5 lbs (incl. parachute) must use additional trim ballast plates. Please refer to the Mass and Balance Form in Section 6 and the description of trim ballast plates in Section 7.11.

In addition the minimum cockpit load is shown in the Operating Limitations Placard in the cockpit (DATA and LOADING PLACARD).

2.9 Kinds of Operation

Flights may be carried out in daylight, in accordance with VFR. Cloud flying is prohibited in Canada!

Rev.No. / Date Sig.
TN 5 / 30.01.92 Juw

Author Date
Waibel March 89

Page No.
2.7
LBA-App.

2.10 Minimum Equipment

Minimum Equipment consists of:

- 1 x ASI indicating up to at least 300 km/h (162 kts)
- 1 x Altimeter
- 1 x 4-part safety harness (symmetrical).
- 1 x Magnetic Compass

Approved equipment is listed in the Maintenance Manual in Section 12.1.

2.11 Aerotow and Winch Launching

The maximum permissible launch speeds are:

- For Aerotow 180 km/h (97 kts)
- For Winch Launch 140 km/h (75,5 kts)

For both types of launch, a weak link of 560 to 660 daN (1235 to 1455 lbs.) must be used in the launch cable or tow rope.

For Aero Tow, the tow rope must be not less than 40 m = 130 ft or more than 60 m = 200 ft in length.

Rev.No. / Date Sig.
TN 5 / 30.01.92 Juw

Author Date
Waibel March 89

Page No.
2.8
LBA-App.

2.12 Limitations Placards

This placard is fixed to the right-hand cockpit side wall and contains the most important mass (weight) and speed limitations.

Segelflugzeugbau A. Schleicher GmbH & Co. Poppenhausen	
Model: ASW24	S.No.: 24 XXX
DATA and LOADING PLACARD	
Empty Mass (Weight):	kg
Max. Mass (Weight):	1102 lbs. 500 kg
Min. Cockpit Load:	kg
Max. Cockpit Load:	kg
Maximum Speeds:	
Auto or Winch Launch W/L:	75.5 kts. 140 km/h
Aerotow A/T:	97 kts. 180 km/h
Operating Landing Gear:	110.6 kts. 205 km/h
Maneuvering Speed:	110.6 kts. 205 km/h
	1235 to 1455 lbs.
Strength of Weak Link for A/T and W/L:	560 to 660 daN
Tire Pressure: Main Wheel:	34 to 37 psi 2.4 to 2.6 bar
Tail Wheel:	34 to 37 psi 2.4 to 2.6 bar

**REDUCED MINIMUM COCKPIT LOAD
WITHOUT TRIM BALLAST IN THE FIN:
SEE FLIGHT MANUAL - PAGE 6.4 !**

Reduction of Minimum Cockpit Load by means of removable trim ballast plates mounted in the front part of the cockpit :- see Section 7.11.

The baggage load in the upper compartment may not exceed 15 kg = 33 lbs., in the lower 10 kg = 22 lbs.

BAGGAGE COM- max.15kg
PARTMENT LOAD (33 lbs.)

BAGGAGE COM- max.10kg
PARTMENT LOAD (22 lbs.)

Rev.No./Date Sig.
TN 5 / 30.01.92 Juw

Author Date
Waibel March 89

Page No.
2.9
LBA-APP.

SECTION 3

- 3. Emergency Procedures
- 3.1 Introduction
- 3.2 Canopy Jettison
- 3.3 Bailing Out
- 3.4 Stall Recovery
- 3.5 Spin Recovery
- 3.6 Spiral Dive Recovery
- 3.7 Other Emergencies

Rev.no./Date Sig.

Author Date
waibel March 89

Page no.
3.1
LBA-APP.

3.1 Introduction

Section 3 provides checklist and amplified procedures for coping with emergencies that may occur.

Brief head-words are followed by a more detailed description.

EMERGENCY PROCEDURES

(1) To Jettison Canopy

- Pull both the left and right-hand red levers at the canopy frame back all the way and
- push canopy UP!

(2) Bailing Out

- Push instrument panel UP
- release safety harness
- roll over cockpit side
- push off strongly
- watch wings and tail surfaces!
- pull parachute!

(3) Spinning

- (a) apply opposite rudder and at the same time
- (b) relax back pressure on stick until rotation stops
- (c) centralise rudder and immediately pull out gently from dive !

Rev.no./Date	Sig.	Author	Date	Page no.
		Waibel	March 89	3.2 LBA-App.

3.2 Jettisoning of Canopy

Pull canopy jettison (red levers mounted left and right at canopy frame) and push canopy away upwards!

3.3 Bailing Out

If bailing out becomes inevitable, first jettison canopy and only then release safety harness.

Push instrument panel UP (if this was not done in the course of jettisoning the canopy). Get up or simply roll over cockpit side.

When jumping, push yourself away from the aircraft as strongly as possible. Try to avoid contact with wing leading edges or tail surfaces!

3.4 Stall Recovery

In straight or circling flight, relaxing of back pressure on the stick will always lead to recovery.

Due to its aerodynamic qualities the ASW 24 will immediately re-gain flying speed.

If opposite aileron is applied during stalled 'mushing' flight, the ASW 24 will roll outwards a little as back pressure is relaxed.

Rev.no./Date	Sig.	Author	Date	Page no.
		Waibel	March 89	3.3 LBA-App.

3.5 Spin Recovery

- (1) Apply opposite rudder (i.e: in the direction opposite to the rotation of the spin) and at the same time
- (2) relax back pressure on the stick until rotation stops
- (3) centralise rudder and gently pull out of the dive.

CAUTION:  Spinning is not noticeably affected by extending the airbrake paddles, but it will increase the height loss when pulling-out, and is therefore inadvisable.

3.6 Spiral Dive Recovery

Depending on the aileron position during spinning with forward C.G. positions - that is: the C.G. range when the ASW 24 will no more sustain a steady spin - it will immediately or after a few turns develop a spiral dive, or a slipping turn similar to a spiral dive.

These conditions will both be terminated by:

- (1) applying opposite rudder
- (2) applying aileron opposite to direction of turn.

Rev.no./Date	Sig.	Author	Date	Page no.
		Waibel	March 89	3-4 LBA-APP.

3.7 Other Emergencies

(1) Emergency Landing with retracted landing gear

Emergency landings with retracted landing gear are disadvised in principle, as the capacity for energy absorption of the fuselage is many times less than that of the sprung landing gear. If the wheel cannot be lowered, the ASW 24 should be touched down with airbrakes closed as far as possible, at a shallow angle and without stalling on to the ground.

(2) Groundloops

If the aircraft threatens to roll out beyond the intended landing area, the decision should be made not less than 40 m = 130 ft before reaching the end of the landing area to initiate a controlled ground loop.

- If possible, turn into wind!
- When putting down a wing, at the same time push the stick forward and apply opposite rudder!

(3) Emergency Landing on Water

A landing on water by a plastic glider with wheel retracted has been experimentally tried out. The experience gained on that occasion suggests that the aircraft will not skim across the water, but that the whole cockpit area will be forced under the surface. If the depth of the water is less than 2 m = 6,5 ft, the pilot is in the greatest danger. Touching down on water is, therefore, recommended only with wheel lowered, and only as a very last resort.

Rev.no./Date	Sig.	Author	Date	Page no.
		Waibel	March 89	3-5 LBA-APP.

(4) Flying with Defective Water Ballast Drainage

The electric valve operation ensures that, when water ballast is jettisoned, both tanks are drained at the same time. [This applies to the electrical operation (ASW 24) as well as for the mechanically operated versions (ASW 24B) and Mr. Hank Nixon's US-version]. This is necessary for reasons of flight characteristics.

When jettisoning water ballast in flight, it should be positively ensured that the water is draining from both wings. The jettisoning of the waterballast can be seen from inside the cockpit.

If a failure of the valves should cause asymmetric loads, the flight should be terminated with extreme care, maintaining an adequate margin above stalling speed as incipient or full spins with asymmetric ballast load are not permissible. Special care should be taken to avoid turning in the direction of the heavier wing.

If a drain valve is defective, the matching valve on the opposite side must be closed, as a landing at a higher landing weight is to be preferred.

Rev. No. / Date	Sig.	Author	Date	Page No.
TN09/ 23.06.94	Juw	Waibel	March 89	3.6

LBA-APP.

SECTION 4

4. Normal Procedures

4.1 Introduction

4.2 Rigging and Derigging

4.3 Daily Inspection

4.4 Pre-Flight Inspection

4.5 Normal Procedures and Recommended Speeds

4.5.1 Winch Launch

4.5.2 Aero Tow

4.5.3 Flight

4.5.4 Approach

4.5.5 Landing

4.5.6 Flight with Water Ballast

4.5.7 High Altitude Flight

4.5.8 Flight in Rain

4.5.9 Aerobatics

Rev. no. / Date	Sig.	Author	Date	Page no.
		Waibel	March 89	4.1

LBA-APP.

4.1 Introduction

Section 4 provides checklist and amplified procedures for the conduct of normal operation. Normal procedures associated with optional systems can be found in Section 9.

4.2 Rigging and Derigging

To rig: The ASW 24 can be rigged without use of rigging aids by three people, or by two people if a fuselage cradle and wing trestle are used.

Note: Exchange the winglets for the wingtip only after rigging the wings to the fuselage!

1. Clean and lubricate all pins, bushings and control connections.
2. Support fuselage and keep upright. If the wheel is lowered, check that the landing gear is securely locked down.
3. Insert right wing spar fork into fuselage and support the wingtip with a trestle, if available. While rigging, the airbrake paddles should be retracted and the ailerons slightly raised.
4. Insert left wing spar root and line up the main pin bushings. Insert and lock main pins. Only now - and not before - may the wing weight be relaxed. If the aircraft is still supported in a fuselage cradle, it is recommended that the

Rev.No./Date Sig.
TN 6 / 18.08.92 Juw

Author Date
Waibel March 89

Page No.
4 - 2
LBA-App.

landing gear should be extended at this stage, and rigging completed with the aircraft standing on its wheel.

5. After cleaning and lightly lubricating the elevator studs and sockets, the tailplane is pushed onto the fin from the front. Each half-elevator must be guided into the elevator connections. The elastic lip seal covering the elevator gap must be placed on top of the elevator control tongue. Now push the tailplane home until the hexagon socket head bolt at the leading edge will engage its thread. The bolt must be fully and firmly tightened. It is secured by means of a spring ball catch, whose ball must engage in the grooves on the side of the bolt head.
6. A considerable performance improvement can be achieved with little effort by taping all gaps at the wing junctions with plastic self-adhesive tape (on the non-moving parts only). The fin-tailplane junctions should also be taped up. The canopy rim must not be taped over, so as not to impair bail-out. It is recommended that appropriate areas should be thoroughly waxed beforehand, so that the adhesive tape can afterwards be cleanly removed without lifting the paint finish.
7. Connect both vent tubes from the wing tanks to the openings at top of the baggage compartment.
8. Now use the Check List (see the following para. 4.4) to carry out the pre-flight check. Under

Rev.no./Date Sig.

Author Date
Waibel March 89

Page no.
4 - 3
LBA-App.

Point 3. "(Control gaps in flight direction must have a clearance of min. 1.5 mm = 1/16 in)", check that the ailerons have that minimum clearance from the inboard and outboard cut-out edges.

This clearance is necessary to ensure that these surfaces do not foul the wing cut-out edges when deformed under load in flight.

9. Optional, the winglets may be exchanged for the wingtips, must be safetied (twisting DZUS-fastener) and taped.

To de-rig: proceed in the reverse order of rigging. We would add the following suggestions:

1. Drain all water ballast. Ensure that all the water has emptied out by putting down alternative wingtips several times.
2. If the tailplane is very firmly located in its rear seating, it will be more easily dismantled by two people alternately pushing it forwards by the tips.
3. Do not forget to disconnect the ballast tank vent tubes before de-rigging the wings! If installed, exchange winglets for wingtips and safety (twisting DZUS-fastener).

4.3 Daily Inspection

Before commencing flying operations, the aircraft must be thoroughly inspected and its controls checked; this also applies to aircraft kept in the hangar, as experience shows them to be vulnerable to hangar-packing damage and vermin.

Rev.No./Date Sig.
TN 6 / 18.08.92 Juw

Author Date
Waibel March 89

Page No.
4 - 4
LBA-App.

- 1- Open canopy and check canopy jettison.
 - Main pins home and secured?
 - Check positive control connections - ailerons, elevator and airbrakes - in fuselage/wing mounting area.
 - Check cockpit and control runs for loose objects or components.
 - Check full, free and stress-free operation of all controls.
Hold controls firmly at full deflection while loads are applied to control surfaces.
 - Check ventilation opening and - if installed - pitot tube (optional extra) in fuselage nose.
 - Check condition and operation of towing hook(s). Release control operating freely? Don't forget release checks!
 - Check wheel brake for operation and leaks. With airbrake paddles fully extended the resilient brake pressure from the main brake cylinder should be felt through the brake handle.
- 2- Check both upper and lower wing surfaces for damage.
- 3- Ailerons:
Check condition and full and free movement (control surface clearances). Check linkage fairing for clearance.

Rev.no./Date Sig.

Author Date

Page no.

Waibel March 89

4 - 5
LBA-APP.

- If installed: Are the winglets undamaged and safetied?
- 4- Airbrake paddles:
Check condition and control connections. Do both sides have good over-center lock?
- 5- Check inflation and condition of tires:
Main wheel : 2.5 bar +/- 0.1 bar
(= 35,6 psi +/- 1,5 psi)
Tail wheel : 2.5 bar +/- 0.1 bar
(= 35,6 psi +/- 1,5 psi)
- 6- Check fuselage, especially underside, for damage.
- 7- Check that static ports in the fuselage tail boom are unobstructed.
- 8- Check the pressure port in the fin :
is the probe properly seated and tight ?
- 9- Check that the tailplane bolt is tight and locked.
- 10- Check that rudder, tailplane and elevator are correctly fitted, and for damage or excessive play.

The numbers against the above points correspond with those in the following illustration "Tour of Inspection".

4.3.1 Tour of Inspection round the Aircraft

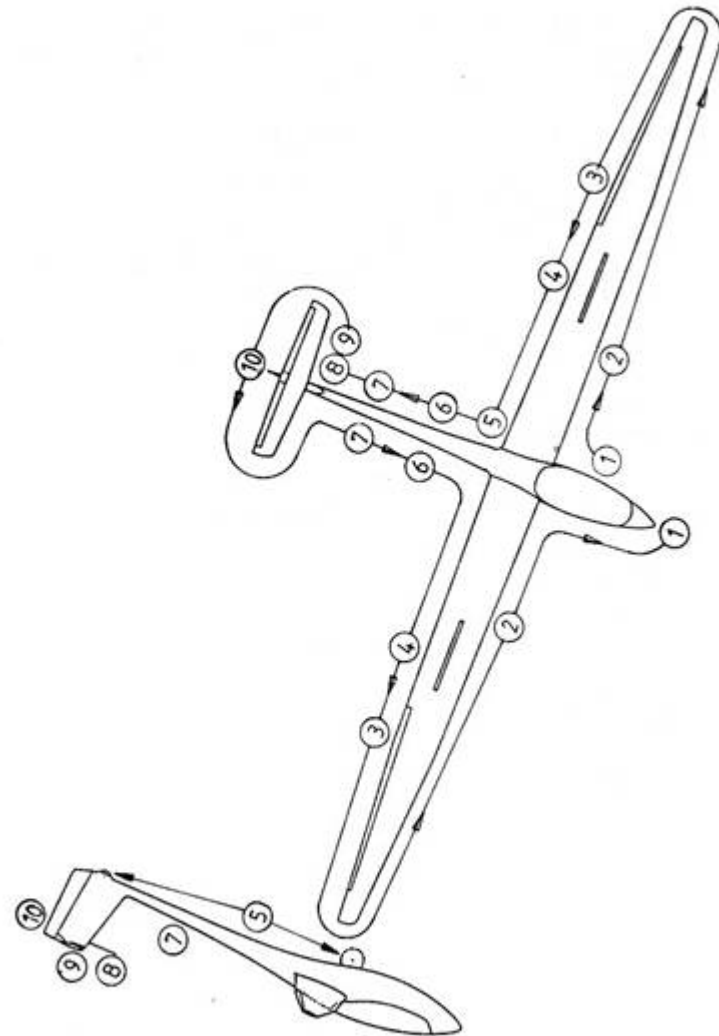

4.4 Pre-Flight Inspection

The following Check List containing the most important points is affixed within easy view of the pilot, below the instrument pod:

Pre-Flight Checks

1. Main pins fully home and secured?
Tailplane bolt fitted?
2. Controls checked for positive connections and
3. Control gaps in flight direction must have a clearance of min. 1.5 mm (1/16 in) !
4. Parachute ripcord connected?
5. Check C.G. position! (Battery in fin? Trim ballast plates in fuselage nose?)
6. Comply with Loading Placard !
7. Water tank drain and vent openings, and pressure ports unobstructed?

Pre-Take-Off Checks:

1. Parachute clipped on?
2. Safety Harness secure and tight?
3. Wheel locked down?
4. Airbrakes closed and locked?
5. Trim set for Take-Off?
6. Altimeter set?
7. Tail dolly removed?
8. Check wind direction!
9. Close and lock canopy!

4.5 Normal Procedures and Recommended Speeds

4.5.1 Winch Launch

It is recommended that the trimmer should be set at the center of the indicator or slightly nose-heavy at any C.G. position. At this trim setting the ASW 24 will assume a gentle climb attitude. Above a minimum safe height the climb should be steepened by applying back pressure on the stick.

A weak link of 560 to 660 daN must be used in the launch cable. Maximum acceptable crosswind component is 25 km/h = 13,5 kts.

NOTE: The wheel should not be retracted during the launch.

CAUTION: Winch launching with water ballast is not recommended at less than 20 km/h = 10,5 kts headwind component. The winch driver must be informed of the total Take-Off Mass.

CAUTION: Before Take-Off, check seating position and that controls are within reach. The seating position, especially when using cushions, must preclude the possibility of sliding backwards during initial acceleration or steep climb.

ASW 24 Flight Manual

WARNING:  We expressly warn against attempting any launch by an under-powered winch in a tail wind!

4.5.2 Aero Tow

The trim should be set nose-heavy. A tow rope of between 40 m and 60 m = 130 ft and 200 ft long, but never less than 40 m in length should be used.

At the start of the take-off run it has proved useful to open the airbrakes fully at first. This prevents over-running the tow rope as slack is taken up, and the tendency for the glider to swing due to one-sided prop wash is considerably reduced. As the ailerons become effective during the ground run, the airbrakes should be promptly closed and locked.

For the actual lift-off, the following practise has proved satisfactory:

Try to keep the tail wheel in contact with the ground until the aircraft lifts off; this increases directional stability during the ground run, and helps the glider to lift off at the earliest possible moment.

After lift-off, climb to between 1 m and 2 m = 3,5 ft and 6,5 ft in order to avoid pitch oscillations caused by ground effect and slipstream turbulence from the tug.

NOTE:  Inform tug pilot of minimum towing speed.

Rev. no./Date	Sig.	Author	Date	Page no.
		Waibel	March 89	4-10 LBA-APP.

ASW 24 Flight Manual

Take-Off Mass	Recommended Towing Speed
300 kg (661,5 lbs)	115 km/h (62,0 kts)
400 kg (882,0 lbs)	120 km/h (64,8 kts)
500 kg (1102,5 lbs)	125 km/h (67,5 kts)

Maximum acceptable crosswind component: 25 km/h = 13,5 kts.

4.5.3 Flight

In straight flight with clean wings and at a flight mass of about 340 kg = 749,7 lbs the ASW 24 will enjoy laminar flow within a speed range of 75 km/h to 160 km/h = 40,5 kts to 86 kts. At the maximum flight mass of 500 kg = 1102,5 lbs the favourable aerodynamic range lies between 90 km/h and 190 km/h = 48,5 kts and 102,5 kts. Beyond these speed ranges, flight performance will noticeably deteriorate.

When circling, remember that the stalling speed will increase compared to that in straight flight. As a general guideline, you should expect the stalling speed to increase by 10 % at about 30° bank, and by 20 % at about 45° bank - see also Section 5.2.2.

CAUTION:  Flights in conditions conducive to lightning strikes must be avoided as the ASW 24 is not approved for such conditions.

Low Speed Flight and Stalling Behaviour

The ASW 24 behaves normally in slow and stalled flight. In all C.G. positions, flow detachment at the fuselage and a gentle oscillation about the vertical axis will give warning of an impending stall. At the foremost C.G. position, the stall character-

Rev.No./Date	Sig.	Author	Date	Page No.
TN07/ 25.04.94	Juw	Waibel	March 89	4-11 LBA-APP.

ASW 24 Flight Manual

istics become very gentle, as the limited elevator deflection will no longer allow maximum angles of attack to be reached.

At this C.G. position, only a gentle stall warning will be experienced, but large aileron deflections can be applied without dropping a wing.

Even with rearmost C.G. position, about half of maximum aileron deflection can still be applied, with rudder centralised, to maintain the aircraft in straight stalled flight. It would, of course, be more appropriate to control the aircraft by means of rudder alone, and to leave the ailerons centered.

Violent applications of rudder or aileron would result in a spiral dive, spinning or side slipping, depending on C.G. position.

If winglets are installed, stall warning as well as transition into stalled attitude are more distinctly noticeable.

CAUTION: Height loss due to incipient spin from straight or circling flight depends largely on the all-up flight mass!

! Height loss from straight flight after prompt recovery action - ≈ 20 m (65,5 ft) !!

! Height loss from circling flight - up to 100 m (328 ft) !!

Rev.No./Date Sig.
TN 6 / 18.08.92 Juw

Author Date
Waibel March 89

Page No.
4.12
LBA-App.

ASW 24 Flight Manual

More specifically, the following would apply:

C.G. Position	Rudder & Aileron Co-ordinated	Rudder & Aileron Crossed
rearmost	steady spin	steady spin
center	spin, leading to spiral dive	spin, leading to side slipping
foremost	\approx half turn of spin, leading to spiral dive	side slipping

Wing drop from circling flight is not noticeably more violent than from straight flight.

For operation with winglets installed no significant change of spin behaviour has been observed.

4.5.4 Approach

Make the decision to land in good time and, notwithstanding the high performance, lower the wheel at not less than 150 m \approx 500 ft agl.

For the remainder of the circuit, maintain about 95 km/h = 51 kts (yellow triangle on ASI scale).

The glider should be trimmed to between 90 and 100 km/h = 48,5 and 54 kts. In turbulence, the approach speed should be appropriately increased.

Rev.No./Date Sig.
TN 6 / 18.08.92 Juw

Author Date
Waibel March 89

Page No.
4.13
LBA-App.

ASW 24 Flight Manual

The double-paddle air brakes are normally effective in controlling the glide angle.

Side slipping with the ASW 24 is very effective and may therefore also be used for controlling the glide angle.

Side slips can be performed between 90 km/h and 120 km/h IAS (49 to 65 kts) by gently applying rudder and opposite aileron control at the same time. With increasing speed less aileron deflection is necessary to achieve a straight flight path despite the rudder is fully deflected. The yaw angles and consequently the additional drag decrease with increasing speed. In a stationary side slip the ASI reading is not usable as it reads between 50 km/h (27 kts) and zero. The correct flying speed is controlled by pitch altitude. The upper edge of the instrument panel must not rise above a horizon position as known from thermal flight altitude.

If the ASW 24 is operated with winglets installed, in side slips greater yaw angles associated with lower bank angles are observed. Associated negative rudder control force gradients and rudder lock can be easily overcome by moderate pedal forces or by easing the control stick into a more neutral position.

NOTE: Side slipping should be practised from time to time at a safe height!

4.5.5 Landing

In an emergency (e.g. abandoned take-off), structural strength will prove adequate to a landing at maximum all-up mass.

However in normal operation it is strongly recommended that the water ballast is jettisoned before landing, in order to increase the safety margin.

Remember to round out in time to allow a clean 2-point touch-down. Immediately before touching down, the airbrake setting may be reduced so as to avoid touching down with wheel brake too firmly applied.

During the ground run the stick should be held fully back; this gives better directional stability in crosswinds, and prevents the tail from lifting due to hard application of the wheel brake.

Rev.No./Date Sig.
TN07/ 25.04.94 Juv

Author Date
Waibel March 89

Page No.
4.14
LBA-APP.

ASW 24 Flight Manual

4.5.6 Flight with Water Ballast

For normal European weather conditions, the wing loading of the ASW 24 is at its best even without additional water ballast.

If achieved lift is markedly greater than 2 m/s = 394 ft/min, wing loading can be increased up to a maximum of 50 kg/m² = 10,24 lb/ft² by use of water ballast.

NOTE: Remember that ballast will increase the stalling speeds and take-off runs.
Ensure that the condition of the airfield, the length of take-off run available and the power of the tug permit a safe launch.

Filling of Water Ballast

The water ballast switch in the cockpit should be turned UP (valve open position). The two green LEDs will now light up (see also Section 7.8).

Start by filling the tank of the wing with its tip on the ground. The tank venting is so designed that in this way the tank will be well vented. The other tank is filled with the wing up, as both valves can only be opened together, at the same time. This is an important LBA requirement, to prevent inadvertent draining of only one tank.

With wings level, carry out a balancing test to

Rev.no./Date Sig.

Author Date
Waibel March 89

Page no.
4.15
LBA-APP.

check that the ballast loads are even. Should one wing prove to be heavier, block the drain hole of the lighter wing briefly by hand while opening the valves until equilibrium is achieved.

WARNING:

It is expressly prohibited to use pressurised water (mains, immersion pumps &c) for filling ballast tanks due to possible damage to the wing structure!

It is recommended to fill from slightly elevated, unpressurised containers (on wing or car roof &c). If water under pressure is used, it is essential to interpose an open intermediate vessel (funnel &c), to ensure that the head-of-pressure cannot rise beyond 1.5 m = 4,9 ft.

If the wings are filled to capacity, it can happen that the tanks slowly drain through the vents while the aircraft is parked. In this case we recommend that the wingtips should be supported level, but on no account to tape up the vents !

The maximum permissible water ballast volume can be calculated as follows:-

500 kg = 1102,5 lbs
less - Empty Mass
less - Cockpit Load

= max. water ballast volume (in kg or liters)

You will find a table with precise values in Section 6.2. !

Rev. no. /Date

Sig.

Author

Date

Page no.

Waibel

March 89

4-16
LBA-APP.

Jettisoning of Water Ballast.

To jettison water ballast, the operating lever at the righthand cockpit wall behind the landing gear lever is pushed forward (valve open).

Every time any water is let off, it is most important to look at the wing trailing edges to check that the water is draining at an equal rate from both the opened valves!

We distinguish between two distinct types of circumstance in which ballast is normally released.

1. Partial reduction of wing loading:

The mean rate of drainage amounts to 0.5 l/sec, higher if tanks are full, less if they are nearly empty. After an appropriate lapse of time the valves should be closed.

2. Rapid ballast jettison:

The full tanks take about 5 1/2 minutes - about 340 seconds - to drain. The first half of the ballast will drain in about 2 minutes, while the remainder will take about another 3 1/2 minutes.

Should the ballast fail to drain as intended, the valves should be closed immediately (pull the operation lever backwards); try again to achieve even drainage by operating the valves again or, if icing is suspected, try again after descending into warmer air to achieve a symmetric jettison.

If you do not succeed after several attempts the situation should be regarded as an emergency, and instructions in Section 3.7, (4) (Other Emergencies) should be followed.

Rev. No. /Date Sig.
TN09/ 23.06.94 JuwAuthor Date
Waibel March 89Page No.
4.17
LBA-APP.

WARNING:



Flights in icing conditions are not advised, especially if the aircraft is wet before climbing through icing level. Experience suggests that drops of moisture on the surface will be blown back, lodge in the control gaps, and there dry comparatively slowly.



This may cause the controls to become stiff to operate, or in extreme cases, jam them. A single climb through icing level with a previously dry aircraft, on the other hand, is not likely to impair the use of the controls even if heavy icing-up of wing and tail unit leading edges occurs.



When carrying water ballast, avoid flying above icing level due to the danger of iced-up outlet valves, or in extreme cases bursting of wings due to ice formation.

4.5.8 Flight in Rain

Rain drops, frost and ice impair the aerodynamic qualities and also alter the flying behaviour. Therefore the quoted minimum speeds for straight and circling flight should, in such conditions, be increased by some 10 km/h = 5,5 kts. Air speeds should not then be allowed to drop below these values.

Rain drops should be removed from a wet aircraft before take-off.

Do not fly into icing conditions with a wet aircraft. In this context, see also para 4.5.7. above.

Rev.no./Date	Sig.	Author	Date	Page no.
		Waibel	March 89	4 - 19 LBA-App.

4.5.9. Aerobatics (only approved without winglets installed)

In accordance with JAR-22.3 some simple aerobatic maneuvers may be permitted for the Utility Category, provided they are demonstrated by appropriate substantiation in the course of type approval tests.

As a steady spin is only possible with aft C.G. positions, the spin is not a suitable aerobatic maneuver. This is because with central and forward C.G. positions the ASW 24 cannot be held in a spin.

The following maneuvers have been demonstrated and are approved:

Lazy Eight:



This figure may be flown at entry speeds of 150 km/h = 81 kts and more at the point of intersection. It is, however, easier to fly this maneuver at an entry speed of about 180 km/h = 97 kts, and it will also look better. A woollen thread on the canopy is very useful in avoiding side slipping.

Chandelle (climbing):



Recommended entry speed is $V_a = 205 \text{ km/h} = 110,5 \text{ kts}$ (end of the green arc on the ASI scale), but not less than $190 \text{ km/h} = 102,5 \text{ kts}$. Vertical climb must be reached by $\approx 160 \text{ km/h} = 86,5 \text{ kts}$. At this speed and in that flight attitude

Rev.No./Date	Sig.	Author	Date	Page No.
TN 6 / 18.08.92	Juw	Waibel	March 89	4 - 20 LBA-App.

it becomes necessary to start applying forward pressure on the stick and begin rolling out to get the wings level to avoid the maneuver ending in a stall.

Stall Turn: For the stall turn the recommended entry speed is also $V_A = 205 \text{ km/h} = 110,5 \text{ kts}$. While pulling up vertically full rudder must be applied at the latest by the time the indicated air speed has reduced to $135 \text{ km/h} = 73 \text{ kts}$ to ensure a clean Stall Turn and not fall into a slipping tail slide.



Steep turns: in a steep turn at 75° bank the minimum speed is $140 \text{ km/h} = 75,5 \text{ kts}$ and an acceleration of 4 g is imposed. It is therefore recommended that steep turns should be carried out with not more than 60 to 70° of bank at about $160 \text{ km/h} = 86,5 \text{ kts}$ to avoid flow detachment at the wing (High Speed Stall).

Loop (positive): A positive loop may be flown at an entry speed at the lowest point from $180 \text{ km/h} = 97 \text{ kts}$, but a speed of $200 \text{ km/h} = 108 \text{ kts}$ is recommended. The required g-load is well below the permissible maximum value of 5.3 g .



Winglets improve the flight performance only for the low speed range but not at very high speeds. They also increase the directional stability. Both qualities are not desirable for aerobatics. Therefore, winglets were not tested and consequently not approved for aerobatics.

Rev.No./Date	Sig.	Author	Date	Page No.
TN 6 / 18.08.92	Juw	Waibel	March 89	4.21
				LBA-App.

SECTION 5

5. Performance

5.1 Introduction

5.2 LBA-Approved Data

5.2.1 Airspeed Indicator System Calibration

5.2.2 Stall Speeds

5.3 Additional Information

5.3.1 Demonstrated Crosswind Performance

5.3.2 Flight Polar Level Flight

5.3.3 Flight Polar Circling Flight

Rev.no./Date	Sig.	Author	Date	Page no.
		Waibel	March 89	5.1

5.1 Introduction

Section 5 provides approved data for airspeed calibration and stall speeds and non-approved additional information.

The data in the charts has been computed from actual flight tests with the sailplane in good conditions and using average piloting techniques.

5.2 LBA-Approved Data

5.2.1 Airspeed Indicator System Calibration

Upwards of an indication of 80 km/h = 43 kts (without water ballast) or of 90 km/h = 48,5 kts (at max. all-up mass) the ASI will only show a minimal indication error. The deviations are within an under-indication of about 2 to 3 km/h = 1 to 1,5 kts, and therefore within the range of acceptable instrument error of a good ASI. In stalled flight the air speed is greatly under-indicated and the pointer will fluctuate between 0 km/h and about 50 km/h = 0 and 27 kts.

NOTE:

The ASI must take its pitot pressure from the Prandtl-Tube in the fin, and static pressure from the static ports in the fuselage tail boom.

Rev.no./Date	Sig.	Author	Date	Page no.
		Waibel	March 89	5.2 LBA-APP.

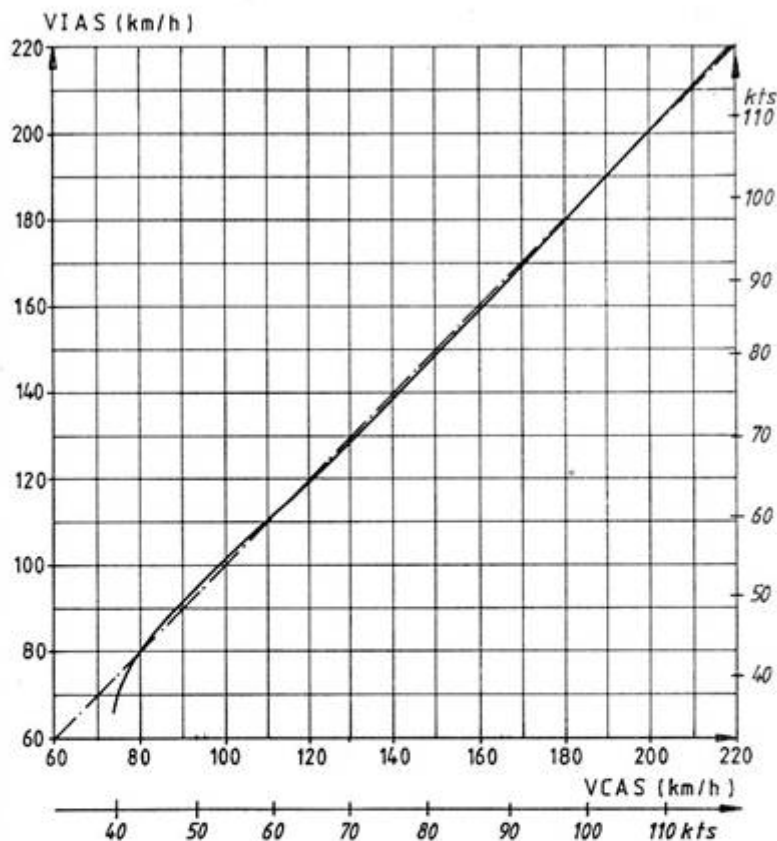

VIAS = Indicated Air Speed

VCAS = Calibrated Air Speed

Rev.no./Date	Sig.	Author	Date	Page no.
		Waibel	March 89	5.3 LBA-APP.

5.2.2 Stall Speeds

Stall Speeds in km/h (kts) Indicated Air Speed.

Air Brake Setting	All-Up Weight kg (lbs)		
	320 kg (705,5 lbs)	410 kg (904 lbs)	500 kg (1102,5 lbs)
closed	65 km/h (35 kts)	73.5 km/h (39,5 kts)	81 km/h (43,5 kts)
open *	71.5 km/h (38,5 kts)	81 km/h (43,5 kts)	89.5 km/h (48,5 kts)

* with landing gear extended !

1. The speeds quoted are valid for the aerodynamically clean glider.
2. Stall warning in the form of tail unit buffeting or gentle oscillation about the vertical axis will commence at about 6 % above the indicated stalling speeds.
3. Extension of air brakes increases the indicated stalling speed in straight flight by about 10 % if the landing gear is extended.
4. But if the landing gear is retracted, and with the air brakes extended, very much lower air speeds may be indicated, i.e. even of about 10 % less than shown in the top line of the table above.

Stalling Speed Diagrams

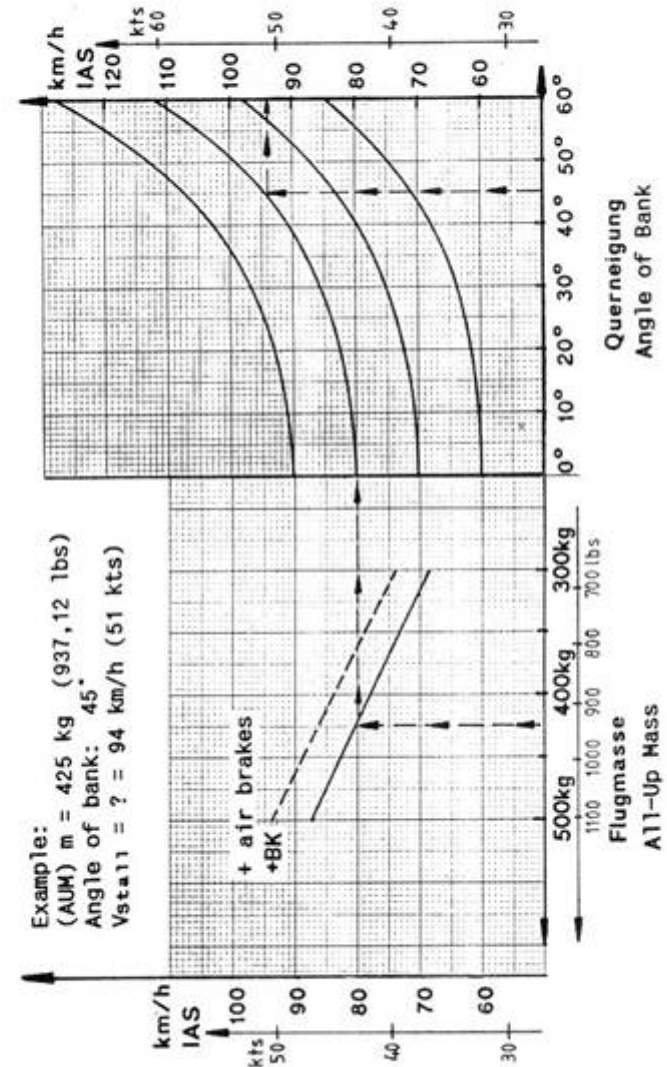

ASW 24 Flight Manual

5.3 Additional Information

5.3.1 Demonstrated Crosswind Performance

Winch Launch 25 km/h = 13,5 kts
 Aero Tow 25 km/h = 13,5 kts
 Landing 25 km/h = 13,5 kts

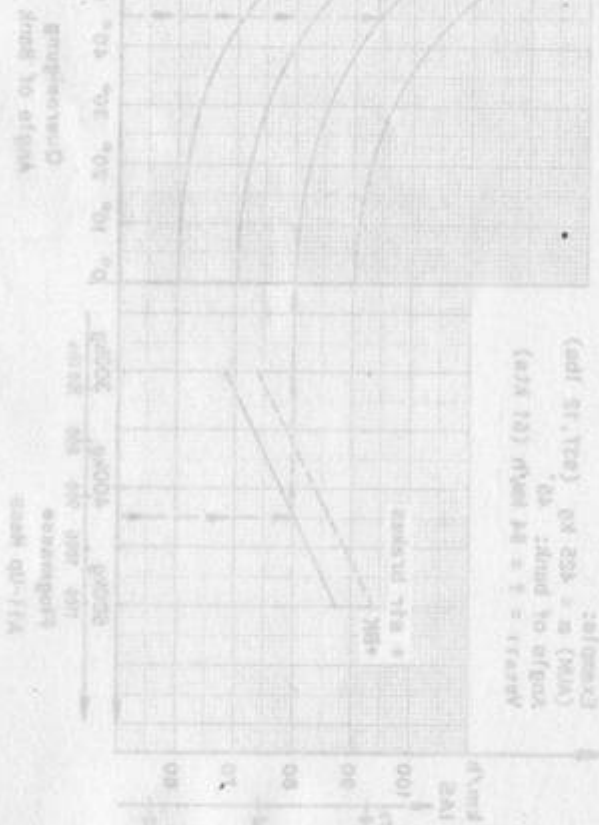

Rev. no. / Date	Sig.	Author	Date	Page no.
		Waibel	March 89	5 - 6

ASW 24 Flight Manual

5.3.2 Flight Polar - Level Flight

The speed polar was calculated, and established in the course of preliminary comparison flights.

Figure 5.3.2-1

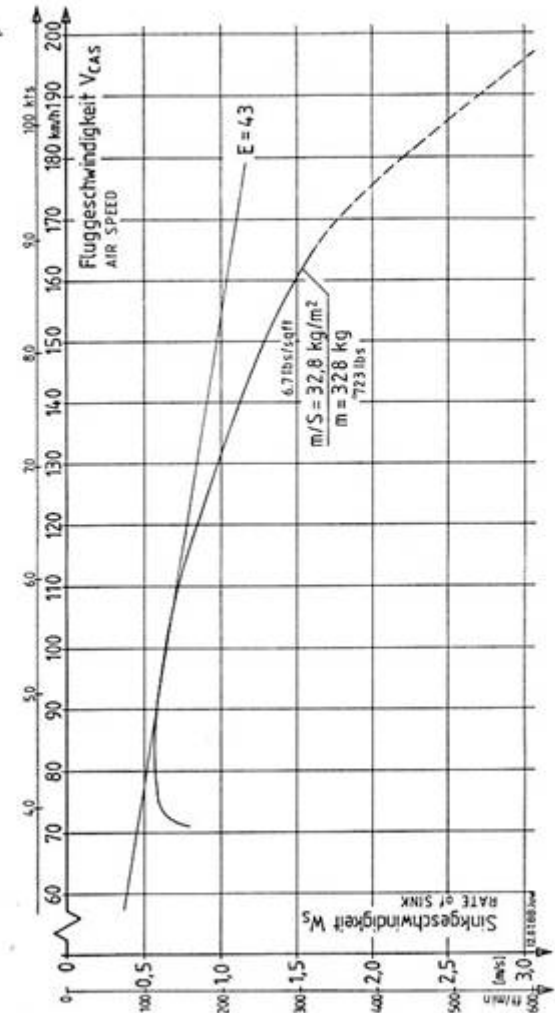

Rev. no. / Date	Sig.	Author	Date	Page no.
		Waibel	March 89	5 - 7

Figure 5.3.2-2

Here the polars calculated for low and high wing loading are shown.

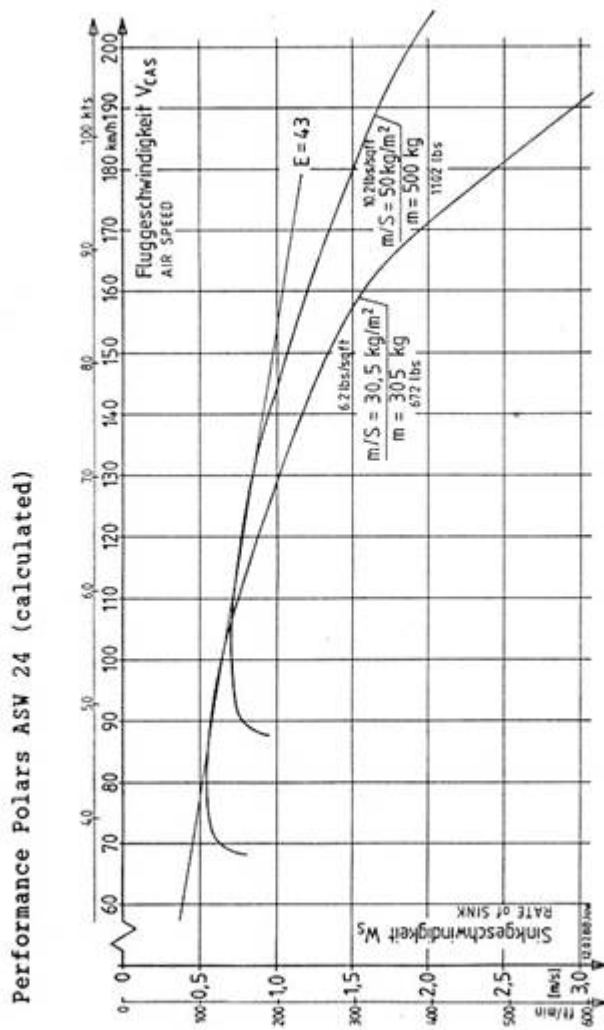

Rev. no. / Date	Sig.	Author	Date	Page no.
		Waibel	March 89	5 - 8

5.3.3 Flight Polar - Circling Flight

The following diagram has been established by calculations based on the speed polars.

Figure 5.3.3-1

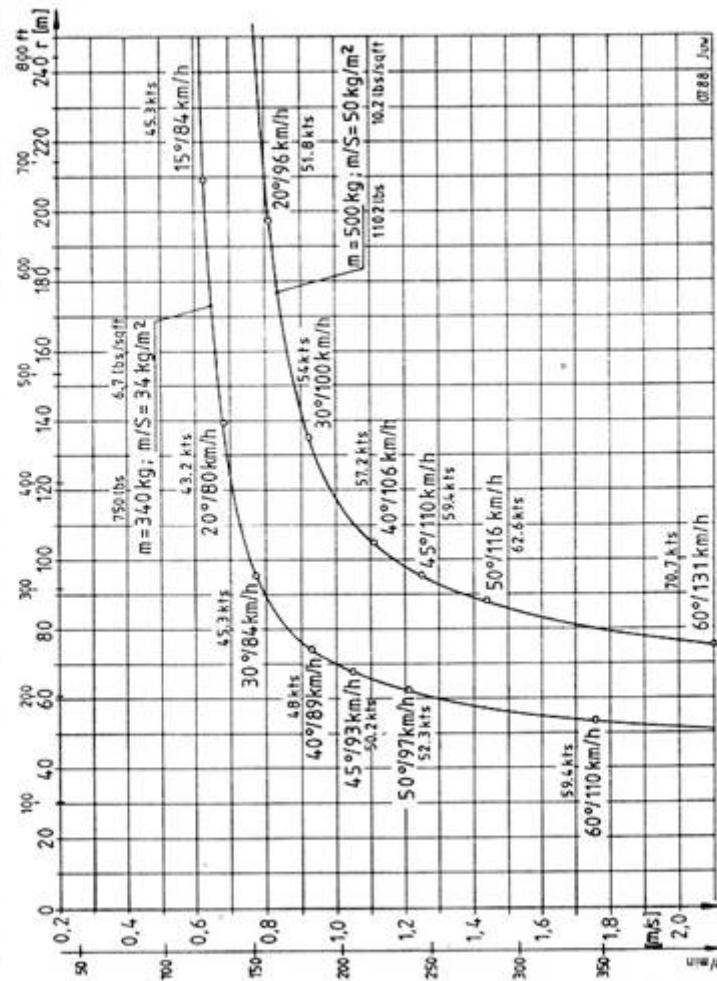

Rev. no. / Date	Sig.	Author	Date	Page no.
		Waibel	March 89	5 - 9

6.1 Introduction

This Section describes the procedures for establishing the basic empty mass and moment of the sailplane.

A comprehensive list of all equipment available for this sailplane is included in the Maintenance Manual, Section 6.

6. Mass (Weight) and Balance / Equipment List

6.1 Introduction

The Mass and Balance Form overleaf shows the maximum and minimum cockpit loads, and any additional load still permissible for the baggage compartment.

These mass and balance data must be calculated in accordance with the currently valid weighing data. The data and diagrams needed for establishing these are to be found in the Maintenance Manual, Section 6.

This Mass and Balance Form is valid only for the aircraft bearing the S.No. shown on the title page of this manual.

If pilot mass is less than the minimum stated in the Mass and Balance Form, this can be rectified by means of trim ballast plates fitted in front of the seat. See also Section 7.11.

Heavy pilots often like to ballast their aircraft for optimum performance to suit their individual weight. A housing is provided for this purpose in

Rev.no./Date	Sig.	Author	Date	Page no.
2.0		Waibel	March 89	6.1

6.1 Introduction

This Section describes the procedures for establishing the basic empty mass and moment of the sailplane.

A comprehensive list of all equipment available for this sailplane is included in the Maintenance Manual, Section 6.

6.2 Mass (Weight) and Balance Form

The Mass and Balance Form overleaf shows the maximum and minimum cockpit loads, and any additional load still permissible for the baggage compartment.

These mass and balance data must be calculated in accordance with the currently valid weighing data. The data and diagrams needed for establishing these are to be found in the Maintenance Manual, Section 6.

This Mass and Balance Form is valid only for the aircraft bearing the S.No. shown on the title page of this manual.

If pilot mass is less than the minimum stated in the Mass and Balance Form, this can be rectified by means of trim ballast plates fitted in front of the seat. See also Section 7.11.

Heavy pilots often like to ballast their aircraft for optimum performance to suit their individual weight. A housing is provided for this purpose in

Rev.no./Date	Sig.	Author	Date	Page no.
		Waibel	March 89	6.2

ASW 24 Flight Manual

the upper part of the fin where trim ballast, for instance in the form of a battery, may be fitted. If any trim ballast is mounted in the fin, the minimum cockpit load will of course be increased ! This increased minimum cockpit load must also be shown in the DATA and LOADING PLACARD in the cockpit. The lower permissible cockpit load without trim ballast in the fin will be shown only on page 6.4 of the Flight Manual.

In the cockpit, an additional placard is to be affixed:

REDUCED MINIMUM COCKPIT LOAD WITHOUT TRIM BALLAST IN THE FIN: SEE FLIGHT MANUAL - PAGE 6.4 !

Sight apertures in the fin make it easy to check whether any trim ballast has been fitted. Clear view through the fin means: No trim ballast fitted! See also Section 7.11.

Rev.no./Date	Sig.	Author	Date	Page no.
		Waibel	March 89	6.3

ASW 24 Flight Manual

MASS AND BALANCE FORM

Date of Weighing	Empty mass C.G. mm aft of RP	Pilot mass incl. chute (kg) min. max.	Load in baggage compart.* (kg)	Inspector's stamp and signature

* Permissible Load in baggage compartment = 245 kg = 507 LBS less empty mass of non-supporting parts less pilot mass less mass of parachute : BUT not more than 25 kg = 55 lbs (15 kg = 33 lbs in upper compartment, and 10 kg = 22 lbs in lower compartment) !!

Rev.no./Date	Sig.	Author	Date	Page no.
TN 2 08.02.90	Juw	Waibel	March 89	6.4

ASW 24 Flight Manual

Maximum Permissible Loading with Water Ballast

Empty Mass kg (lbs)	Pilot mass + parachute + baggage kg and (lbs) :					
	75 (166)	85 (188)	95 (210)	105 (232)	115 (254)	125 (276)
220 (485)	full	full	full	full	full	155 (342)
230 (507)	full	full	full	full	155 (342)	145 (320)
240 (529)	full	full	full	155 (342)	145 (320)	XXX
250 (551)	full	full	155 (342)	145 (320)	XXX	XXX
260 (573)	full	155 (342)	145 (320)	XXX	XXX	XXX
270 (573)	155 (342)	145 (320)	XXX	XXX	XXX	XXX

XXX: These combinations are precluded as they would cause the maximum permissible mass of non-lifting parts to be exceeded!

The water ballast bags fitted in the wings as standard equipment have a total capacity of 130 liters = 34,3 US.Gal.

An approved special version with a capacity of about 155 Liters = 41 US.Gal. can be supplied on request.

Rev.no./Date	Sig.	Author	Date	Page no.	
TN 2	08.02.90	Juw	Waibel	March 89	6 - 5

ASW 24 Flight Manual

SECTION 7

7. Sailplane and Systems Description

- 7.1 Introduction
- 7.2 Airframe
- 7.3 Flight Controls including Trim
- 7.4 Airbrake System
- 7.5 Landing Gear System
- 7.6 Cockpit, Canopy, Safety Harness and Instrument Panel
- 7.7 Baggage Compartment
- 7.8 Water Ballast System
- 7.9 Electrical System
- 7.10 Pitot and Static System
- 7.11 Miscellaneous Equipment
(Removable ballast, Oxygen, ELT, etc.)

Rev.no./Date	Sig.	Author	Date	Page no.
		Waibel	March 89	7 . 1

7.1 Introduction

This Section provides description and operation of the sailplane and its systems. Refer to Section 9, Supplements, for details of optional systems and equipment.

A detailed technical description of the glider with layout drawings can be found in the Maintenance Manual.

The principal purpose of this Section is to describe the controls in the cockpit, their layout and placards.

7.2. Airframe

The wing profile is equipped with "Zig-Zag Tape" on the lower surface for the purpose of controlling the boundary layer. The optimum position and thickness of the tape for various kinds of flight operations are still being determined. In every ASW 24 there is provision for an "air pressure duct" to facilitate the possible installation of "vortex generators".

7.3 Flight Controls including Trim

(1) Aileron and Elevator

Both these controls are operated by means of the control column. The stick is also fitted with the trim release lever for setting the trim, and with the radio transmit button.

Rev.no./Date	Sig.	Author	Date	Page no.
		Waibel	March 89	7.2

(2) Rudder

The rudder pedal is adjustable to suit the length of the pilot's legs.

Pedal Adjustment:
grey knob at Right
of stick.

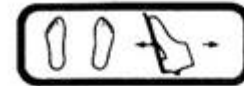

To move pedals forward: pull knob and push pedals forward with your heels. Release knob and push again to lock in position.

To move pedals aft: relax pressure on pedals, pull knob back. Then release knob and apply pressure to pedals to lock in position.

Rev.no./Date	Sig.	Author	Date	Page no.
		Waibel	March 89	7.3

(3) Trim

To set the trim, simply press the trim release lever at the control stick when flying at the desired air speed. A trim indicator is fitted at the left cockpit wall at the seat.

When trim is unlocked by pressing the stick mounted trim release lever, the trim can also be adjusted by sliding at the same time the trim indicator knob to a desired position.



Trim nose heavy



Trim tail heavy

7.4 Airbrake System

The airbrakes are operated by a blue handle mounted at the left cockpit wall.

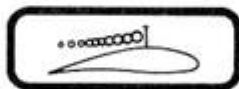

Pull the blue handle to extend the airbrake paddles.

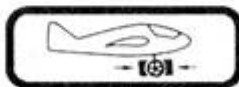

When the airbrake handle is pulled back to its fullest extent, it will also actuate the hydraulic disc brake of the main wheel.

The double-paddle airbrakes extend on the upper wing surface only.

Rev. no. / Date	Sig.	Author	Date	Page no.
		Waibel	March 89	7 - 4

7.5 Landing Gear System

The landing gear is extended and retracted, and locked at either position, by means of the black handled lever mounted at the right-hand cockpit wall.

Landing gear extended
(lever forward)Landing gear retracted
(lever aft)

Tire pressures: Main wheel: 2.5 bar +/- 0.1 bar
(35,6 psi +/- 1,5 psi)

Tail wheel: 2.5 bar +/- 0.1 bar
(35,6 psi +/- 1,5 psi)

7.6 Cockpit, Canopy, Safety Harness and Instrument Panel(1) Launch Cable / Towing Hook Release:

High on the left cockpit wall you will find the :-

yellow cable release
knob.

Pulling the yellow knob will open one or both of the towing hooks.

For the launch cable to be attached, pull the yellow knob back and then merely release it to allow the towing hook to snap shut and lock.

Rev. no. / Date	Sig.	Author	Date	Page no.
		Waibel	March 89	7 - 5

(2) Seat and Seating Positions:

The seat is designed to allow tall and medium sized pilots to sit comfortably, and improve their position by means of cushions and an appropriate choice of parachute. For tall pilots we would recommend the use of thin parachute packs of the new type. Very short pilots will have to adjust their seating position by means of a firm cushion so that all controls are within comfortable reach, that their view to the outside is improved, and that they are prevented from sliding back during initial take-off (winch launch) acceleration.

Very tall pilots may fly without the seat back, but must then fit the covers(*) on the left for the lower baggage compartment (in the Motor Glider version this is the fuel tank cover) and on the right for the oxygen bottle seating tube, and must ensure spinal support by means of a hard foam (e.g. Styropor, Conticell or Rohacell) !

(*) The covers are obtainable as accessories from Schleichers.

(3) Canopy Operation

The canopy is locked by means of the two white lever handles fitted to the canopy frame at the right and left.



These levers are marked by these adhesive labels.

To open the canopy, both levers are pivoted to the rear and the canopy is pushed up.

Rev.no./Date	Sig.	Author	Date	Page no.
		Waibel	March 89	7 - 6



To jettison the canopy, pull jettison levers (red levers mounted at either side of the canopy frame) and push canopy away upwards!

Operating the red jettison levers will automatically open the white locking levers, leaving the canopy resting loose on the cockpit rim.

NOTE:



If possible, do not leave the aircraft parked or unattended with canopy open, because:

1. The canopy could be slammed shut by a gust of wind which might shatter the perspex.
2. At certain elevations of the sun it could act as a lens concentrating the sun's rays, which might ignite cockpit instruments and equipment.

NOTE:



Operating the jettison levers allows the canopy to be removed for easy access when inspecting instruments.

(4) Safety Harness

The safety harness is anchored in such a way that it cannot jam the control runs underneath the seat pan.

The safety harness (seat straps including shoulder straps) should be worn at all times, and should be fully tightened. Check every time that each individual strap is properly secured in the harness lock.

Rev.no./Date	Sig.	Author	Date	Page no.
		Waibel	March 89	7 - 7

The lock should also be tested from time to time to ensure that it can be satisfactorily released under load.

(5) Ventilation



The ventilation flap is located at the front of the canopy frame and is operated by means of the small black knob on the instrument panel. Pull to open.

This flap also serves as a demister.

A further air outlet nozzle is fitted at the right cockpit wall to the right of the instrument panel, which is opened and closed by twisting the rim and the direction of which can also be adjusted. This air outlet should be closed if the demisting function of the front canopy ventilation flap needs to be made more effective.

(6) Instrument Panel

For safety reasons, only a GRP panel made in accordance with the lamination plan specified by the manufacturer may be used.

Instruments weighing more than 1 daN need further support, in addition to the fixing screws provided. This can be done by means of aluminum straps fixed to the instrument pod.

Equipment with operating controls must be fitted conveniently to hand and within reach, even when the safety harness is worn. Flight monitoring instruments, like ASI and altimeter, must be mounted within the pilots field of view.

Rev. no. / Date	Sig.	Author	Date	Page no.
		Waibel	March 89	7 - 8

7.7 Baggage Compartment

Hard objects may not be carried in the upper baggage compartment in front or on top of the spar without a suitably designed lashing or anchorage !

If, for instance, a barograph is to be carried in this space, a mounting approved by the manufacturer must be used. A moulded seating for a 12V/5.6Ah battery is supplied with the glider as standard equipment.

The same applies of course to the lower baggage compartment at bottom left by the main bulkhead beside the wheelbox.

The baggage load in the upper compartment may not exceed 15 kg = 33 lbs, in the lower 10 kg = 22 lbs.

Baggage com- max. 15 kg
partment load (33 lbs.)

Baggage com- max. 10 kg
partment load (22 lbs.)

Rev. no. / Date	Sig.	Author	Date	Page no.
		Waibel	March 89	7 - 9

7.8 Water Ballast System

The water ballast valves in the wings are operated mechanically. The operating lever is situated at the righthand cockpit wall behind the landing gear lever.



Pushing the lever forward opens both valves in the wings at the same time.

By combining the operation of left and right tank with one lever only, an inadvertent opening of only one valve, resulting in a one-sided ballast load, becomes impossible.

7.9 Electrical System

The electrical system is supplied by a 12V battery. Each electrical appliance is protected by its own fuse. A fuse is also fitted in the cable connected to the fin-mounted battery, close to the battery.

7.10 Pitot and Static Systems

Pitot pressure is obtained from a Prandtl-tube mounted in the fin. Ensure that this Prandtl tube is fully pushed home in its seating in the fin. The inner end of the probe should from time to time be lightly lubricated with Vaseline or a similar lubricant, in order to save the O-ring gaskets from wear.

At the same time, the Prandtl tube provides air at accurate static pressure which can be used for electrically compensated variometer systems.

Static pressure for the ASI is obtained from the static ports at either side of the fuselage tail boom.

7.11 Miscellaneous Equipment

(1) Removable Trim Ballast

If required, the ASW 24 can be fitted with a moulded seating for lead trim ballast plates which can be bolted into place; the seating goes in the front part of the seat under the pilot's left calf.

In this location, a 3.05 kg = 6,73 lbs lead trim plate equals an additional pilot weight of 5 kg = 11 lbs).

Thus, a pilot weighing 10 kg (22 lbs) less than the minimum cockpit load must fit two trim plates weighing 3.05 kg each.

(2) Trim Mass (Battery) mounted in the fin

If a trim mass (battery) is fitted in the fin, the minimum cockpit seat load will be more than 70 kg = 154,5 lbs (incl. parachute). This increased minimum cockpit load must then be shown in the DATA and LOADING PLACARD in the cockpit.

Any reduced minimum cockpit load when no tail ballast is fitted will be quoted on page 6.4.

For further details of minimum cockpit load see page 2.7 of this manual.

The foam buffer fitted over the battery secures it above. This plastic foam pad must not be forgotten when changing or replacing batteries.

You should also ensure that there is adequate plastic foam seating under the battery to protect it from hard knocks.

Rev.no./Date	Sig.	Author	Date	Page no.
		Waibel	March 89	7.12

(3) Oxygen

The seating for the oxygen bottle is fitted as standard equipment, in the form of the tube at the bottom right in the main bulkhead, beside the wheel-box. A 3-liter bottle of 100 mm dia. will found the most suitable to fit in this opening.

A suitable bottle fixing bracket is required, and is available as an optional accessory with Schleichers.

When fitting the oxygen bottle, ensure that it is properly installed and securely anchored.

NOTE: Fitting of oxygen equipment only causes a minimal change in the empty-mass C.G. position !

(4) Emergency Location Transmitter

The location least vulnerable to damage in case of accident is the area between the two drag spar pins at either side of the fuselage.

Therefore, the emergency location transmitter (ELT) should be fitted to the fuselage wall in the baggage compartment area, in an appropriate mounting.

Since the whole of the air frame except for the fin and a small area above the baggage space contains CRP layers, and carbon fiber laminations screen the transmission radiation, the ELT aerial must be fitted in the area between wing spar and canopy.

Rev.no./Date	Sig.	Author	Date	Page no.
		Waibel	March 89	7.13

SECTION 8

- 8. Sailplane Handling, Care and Maintenance
 - 8.1 Introduction
 - 8.2 Sailplane Inspection Periods
 - 8.3 Sailplane Alterations or Repairs
 - 8.4 Ground Handling / Road Transport
 - 8.5 Cleaning and Care

Rev.no./Date	Sig.	Author	Date	Page no.
		Waibel	March 89	8.1

8.1 Introduction

This Section contains manufacturer's recommended procedures for proper ground handling and servicing of the sailplane. It also identifies certain inspection and maintenance requirements which must be followed if the sailplane is to retain that new-plane performance and dependability. It is wise to follow a planned schedule of lubrication and preventive maintenance based on climatic and flying conditions encountered.

8.2 Sailplane Inspection Periods

A complete inspection should be carried out annually.

Further details are given in the ASW 24 Maintenance Manual, Sections 4 and 7.

8.3 Sailplane Alterations or Repairs

Regarding repairs and modifications, please see ASW 24 Maintenance Manual, Sections 10 and 11.

It is important that the Aviation Authority concerned should be advised before carrying out any modification of the glider which is not yet officially approved. This would ensure that the airworthiness of the aircraft is not invalidated.

Rev.no./Date	Sig.	Author	Date	Page no.
		Waibel	March 89	8.2

ASW 24 Flight Manual

8.4 Ground Handling / Road Transport

(1) Parking

Parking of the aircraft in the open can be recommended only if foreseeable weather conditions remain suitable. It should be seriously considered whether the secure picketing, covering, and cleaning of the aircraft before the next flight may not demand more effort than de-rigging and re-rigging would have done.

For tying-down the wings, trestles (perhaps from the trailer) should be used which ensure that the ailerons cannot be stressed by the picketing ropes.

NOTE: Parking in the open without protection against weather or light will reduce the life of the surface finish. Even after only a few weeks without intensive care the polyester paint finish can become brittle and develop cracks.

If the aircraft is parked in the hangar for protracted periods, it is recommended to cover only the perspex canopy with a dust cover, as dust covers retain moisture in wet weather for long periods. Moisture can impair the dimensional stability and even the strength of all fiber reinforced composites.

For this reason, protracted periods of parking with water ballast on board are also inadmissible!

For longer parking periods, also inside hangars as well as during road transport of the sailplane, the winglets must be derigged. Because of flutter safety reasons they have to be built extremely lightweight and therefore may be easily damaged during rough ground operation.

Rev.No./Date	Sig.
TN 6 / 18.08.92	Juw

Author	Date
Waibel	March 89

Page No.
8 - 3

ASW 24 Flight Manual

When parking, carefully remove any remainders of provisions (chocolate, sweets &c), as experience shows this would attract vermin which could cause damage in and to the aircraft.

(2) Road Transport

Messrs. Alexander Schleicher GmbH can supply dimensioned drawings of the glider which will provide all the measurements needed for building a closed trailer.

We can also supply the names and addresses of reputable trailer manufacturers.

Above all, it is important to ensure that the wings are supported in properly shaped and fitted wing cradles, or at the very least, that the spar ends are securely supported as closely as possible to the root ribs.

Re-inforced points of the fuselage are the main wheel (but remember the suspension springing!), and tail wheel; also possibly the drag spar pins (make up support seatings from plastic material like Nylon!), and the area under the canopy arch.

For an aircraft of this quality and value, an open trailer, even with tarpaulin, cannot be recommended. Only a closed trailer of plastic or metal construction, or with heavy tarpaulin cover, may be considered suitable, which in any case should have light coloured surfaces and be well ventilated also while stationary so as to avoid high internal temperatures or humidity.

Road transport with water ballast on board is not admissible!

Rev.no./Date	Sig.

Author	Date
Waibel	March 89

Page no.
8 - 4

8.5 Cleaning and Care

Contrary to the false assumption that plastic materials are impervious to moisture and ultra-violet light we would state emphatically that even modern gliders need care and maintenance !

(1) Moisture - Effects on the structure of the fiber-reinforced plastics and on the surface finish.

In the long run, moisture will also damage fiber re-inforced composites, as it will penetrate into the epoxy resin base and cause it to swell, which will partially burst the tight cohesion of the plastic molecules.

In particular, a combination of high temperature and high humidity must be avoided ! (As eg: poorly ventilated trailer becoming damp inside, which is then heated by the sun).

Neither the best quality of paint protection on the surfaces, nor the plastic or rubber skins of the water ballast tanks can fundamentally prevent water vapour diffusion; they can only retard the process. If water has entered the airframe and cannot be removed by means of sponge or chamois leather, the aircraft should be de-rigged and dried out, while periodically turning the affected part, in a room which should be as dry as possible, but not too hot.

Rev. no. / Date	Sig.	Author	Date	Page no.
		Waibel	March 89	8 - 5

(2) Sunlight - Effects on the surface finish

Sunlight - especially its UV component - embrittles the white polyester gelcoat and the perspex canopy. The wax layer on the gelcoat will also oxydise and discolour more quickly if the aircraft is unnecessarily exposed to strong sunlight. There is no paint finish on the market as yet which is unrestrictedly suitable for plastic gliders, and would approximate the life span of the plastic structure of the airframe without maintenance.

(3) Care of Surface Finish

As the white polyester gelcoat is protected by a fairly durable wax layer, it will tolerate being washed down from time to time with cold water, with a little cleaning medium added. In normal use, the wax coating need only be renewed annually with a rotary mop. In moderate European conditions it will suffice if on two occasions a paint preservative is used in addition. In areas subject to long and stronger sun exposure this should be done more often.

For the care of the paint finish, only silicone-free preparations may be used (eg: 1 Z-Special Cleaner-D 2 by Messrs. W. Sauer & Co., D-5060 BENSBERG, or Cleaner Polish by Lesonal).

Traces of Adhesive from Self Adhesive Tapes are best removed by means of benzene (petrol is toxic!) or paint thinners. After cleaning, renew the wax coating.

Rev. no. / Date	Sig.	Author	Date	Page no.
		Waibel	March 89	8 - 6

NOTE:

The signal and decorative markings are built up from nitric or acrylic paint; therefore no thinners must be used and even benzene should not be allowed to act on them for prolonged periods.

(4) Canopy

The Acrylic Canopy (Plexiglas or Perspex) should only be cleaned by means of a special cleaner (eg: Plexiklar) or with lots of clean water. On no account should a dry cloth be used for dusting or cleaning.

(5) Safety Harness

The safety harness straps should be regularly inspected for tears, compressed folds or wear, and corrosion of metal parts and buckles. The reliable operation of the release mechanism - even under simulated load - should be tested occasionally.

Rev. no. / Date	Sig.	Author	Date	Page no.
		Waibel	March 89	8 - 7

Introduction 9.1

This section contains additional information designed to facilitate the use of the aircraft. It is equipped with various ancillary systems and equipment not included as standard equipment.

9. Supplements

9.1 Introduction

9.2 List of Ancillary Equipment

9.3 Description of Ancillary Equipment

Description of Ancillary Equipment 9.3

Oxygen installation: (1)

When flying at greater heights while using the oxygen installation, it should be borne in mind that any particular system may only be suitable for a limited altitude range. The manufacturer's instructions should be complied with.

Emergency location Transmitter: (2)

See page 7.13 of this Manual.

Rev. no. / Date	Sig.	Author	Date	Page no.
8 - 7		Waibel	March 89	9 - 1

ASW 24 Flight Manual

9.1 Introduction

This Section contains additional information designed to facilitate safe and effective operation of the glider, if equipped with various ancillary systems and equipment not included as standard equipment.

9.2 List of Ancillary Equipment

- (1) Oxygen system installation
- (2) Emergency Location Transmitter

9.3 Description of Ancillary Equipment

(1) Oxygen installation:

When flying at greater heights while using the oxygen installation, it should be borne in mind that any particular system may only be suitable for a limited altitude range. The makers' instructions should be complied with.

(2) Emergency Location Transmitter:

See page 7.13 of this Manual.

Rev. no./Date	Sig.	Author	Date	Page no.
		Waibel	March 89	9.2

